

**Lavavajillas de apertura frontal  
Lave-vaisselle à ouverture frontale  
Front loading dishwasher  
Geschirrspülmaschinen mit frontbeladung  
Lavastoviglie ad apertura frontale  
Lava-louças de apertura frontal**

**Modelos:**

**AD-64  
AD-64 B  
AD-64 C  
AD-64 D  
AD-64 DD  
AD-64 B DD**

***Diciembre 2009 December***

***Revisado Julio 2013 July Revised***



---

F A G O R I N D U S T R I A L

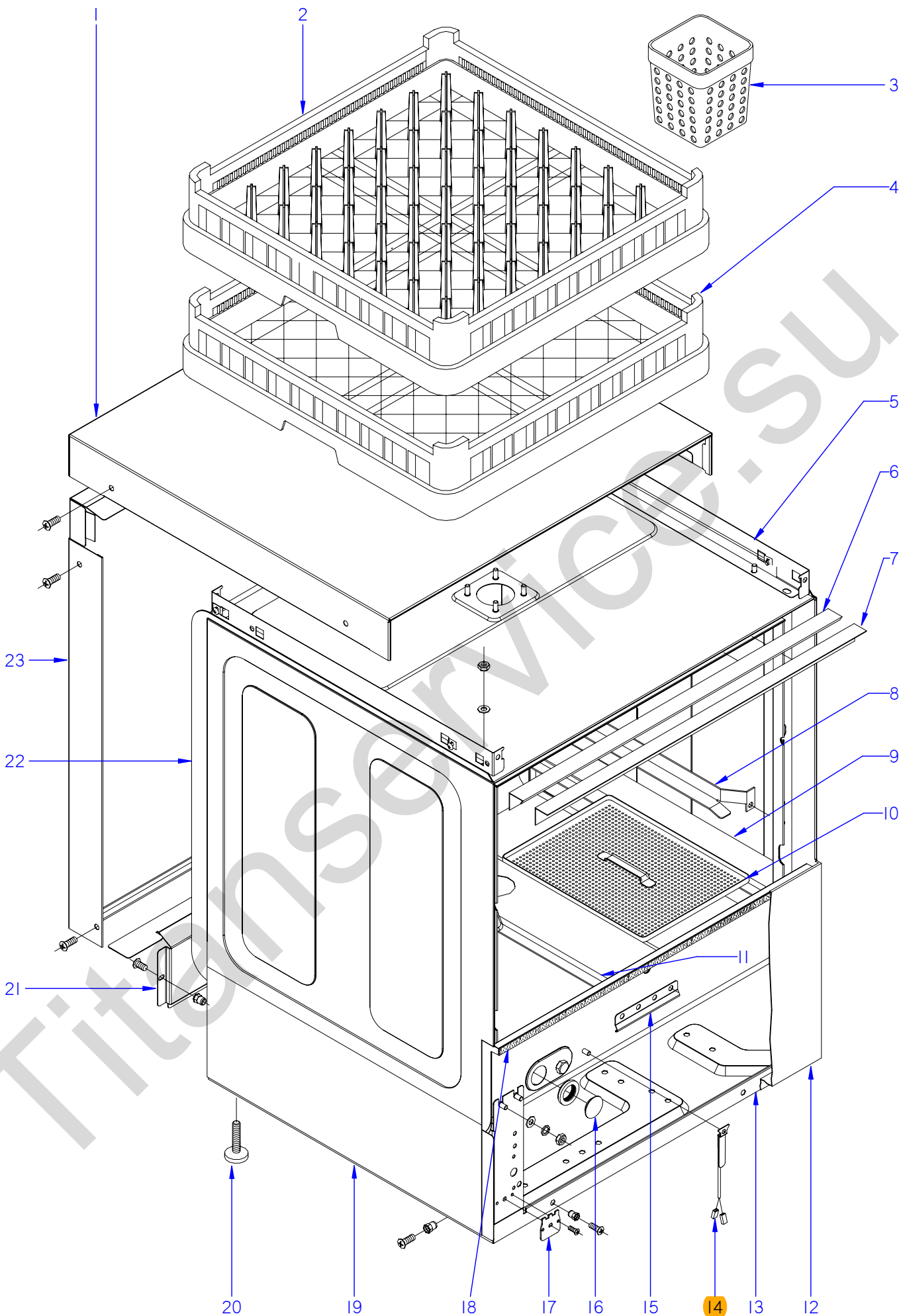

ITEM MARCADO EN COLOR = REPUESTO RECOMENDADO  
 COLOURED ITEM = RECOMMENDED SPARE PART

N plano	Firma	Fecha	Aparato	MUEBLE	Lamina	Fagor Industrial S.Coop. <b>FAGOR</b>
C-2470	<i>(Signature)</i>	2009-12	LAVAVAJILLAS AD-64		1	Oñate

MOD.	LAVAVAJILLAS DE APERTURA FRONTAL	ZONA	MUEBLE	PLANO	C-2470
------	----------------------------------	------	--------	-------	--------

ITEM	CODIGO	DENOMINACION	TEXTO	AD-64	AD-64 B	AD-64 C	AD-64 D	AD-64 DD	AD-64 B DD	NOTAS
1	Z202929000	TAPA AD	COVER	1	1		1	1	1	
1	Z212919000	TAPA DOBLE PARED AD48	COVER AD48			1				
	Q152004000	TORNIL, APLASTADO M5x13 A304	FLAT HEADED BOLT M5x13 A304	6	6	6	6	6	6	
2	Z655302000	CESTILLO PLATOS CP-16-18	BASKET CP-16-18	1	1	1	1	1	1	
3	Z655314000	CESTILLO CUBIERTOS	CUTLERY BASKET	4	4	4	4	4	4	
4	Z655301000	CESTILLO BASE CT-10	BASE BASKET CT-10	1	1	1	1	1	1	
	Z209121000	TOPE 50x50x80	TOP 50x50x80	2	2	2	2	2	2	
5	Z200329000	ESCUADRA AMARRE TAPA AF	FASTENING BRACKET COVER	2	2		2	2	2	ELIMINADO 26.03.10
5	Z200346000	ESCUADRA AMARRE TAPA AF	FASTENING BRACKET COVER	2	2		2	2	2	INTRODUCIDO 26.03.10
5	Z210301000	ESCUADRA AMARRE P.LATERAL	FASTENING BRACKET			2				ELIMINADO 03.05.10
S/Nº	Z210302000	ESCUADRA DOBLE PARED	FASTENING			4				
	Q232040000	ARANDELA A6	WASHER A6	4	4	4	4	4	4	
	Q162040000	TUERCA EXAGONAL M6	HEXAGONAL NUT M6	4	4	4	4	4	4	
	Q221012000	TUERCA RAPIDA M,5	RAPID NUT M,5	6	6	6	6	6	6	
	Q012073000	TORNILLO EXAGONAL M12X20	HEXAGONAL BOLT M12X20	3	3	3	3	3	3	
	Q306024000	JUNTA18X12.5X1.5	SEAL 18X12.5X1.5	3	3	3	3	3	3	ELIMINADO 25,06,2012
	Q162070000	TUERCA EXAGONAL M12	HEXAGONAL NUT M12	3	3	3	3	3	3	
6	Z200315000	PERFIL CAJA	BOX PROFILE	1	1	1	1	1	1	
7	Z200309000	ESCUADRA SUJECCION PERFIL	FASTENING BRACKET PROFILE	1	1	1	1	1	1	
8	Z200305000	GUIA CESTILLO DERECHO	RIGHT BASKET GUIDE	1	1	1	1	1	1	ELIMINADO 01.12.10
8	Z200347000	GUIA CESTILLO DERECHO	RIGHT BASKET GUIDE	1	1	1	1	1	1	INTRODUCIDO 01.12.10
S/Nº	Z200306000	GUIA CESTILLO IZQUIERDO	LEFT BASKET GUIDE	1	1	1	1	1	1	ELIMINADO 01.12.10
S/Nº	Z200348000	GUIA CESTILLO IZQUIERDO	LEFT BASKET GUIDE	1	1	1	1	1	1	INTRODUCIDO 01.12.10
	Q162040000	TUERCA EXAGONAL M6	WASHER A6	4	4	4	4	4	4	
	Q232040000	ARANDELA A6	HEXAGONAL NUT M6	4	4	4	4	4	4	
9	Z210805000	SOPORTE DERECHO BANDEJAS	RIGHT TRAY SUPPORT	1	1	1	1	1	1	
S/Nº	Z210806000	SOPORTE IZDO. BANDEJAS	LEFT TRAY SUPPORT	1	1	1	1	1	1	
	Q162040000	TUERCA EXAGONAL M6	HEXAGONAL NUT M6	4	4	4	4	4	4	
	Q232040000	ARANDELA A6	WASHER A6	4	4	4	4	4	4	
10	Z210802000	BANDEJA COMPLETA	COMPLETE TRAY	4	4	4	4	4	4	
11	Z210804000	SOPORTE CENTRAL BANDEJAS	TRAY SUPPORT CENTRAL	1	1	1	1	1	1	

MOD.		LAVAVAJILLAS DE APERTURA FRONTAL		ZONA	MUEBLE						PLANO	C-2470
ITEM	CODIGO	DENOMINACION	TEXTO	AD-64	AD-64 B	AD-64 C	AD-64 D	AD-64 DD	AD-64 B DD		NOTAS	
12	Z202913000	PANEL FRONTAL SIN PUERTA	FRONT PANEL	1			1	1				
12	Z228812000	PANEL FRONTAL B SIN PUERTA	FRONT PANEL B		1	1			1			
13	Z200101000	ARMAZON COMPLETO	COMPLETE FRAME	1	1	1	1	1	1			
14	Z713028000	SONDA TEMPERATURA GICAR	TEMPERATURA PROBE GICAR	1	1	1	1	1	1			
S/Nº	Z718004000	AMARRE SONDA	PROBE CATCH	1	1	1	1	1	1			
	Q162020000	TUERCA EXAGONAL M4	HEXAGONAL NUT M4	1	1	1	1	1	1			
15	Z748008000	SOPORTE BULBO TERMOSTATO	THERMOSTAT BULB SUPPORT	1	1	1	1	1	1		ELIMINADO 29.02.12	
15	12043725	SOPORTE BULBO TERMO. TANQUE	THERMOSTAT BULB SUPPORT	1	1	1	1	1	1		INTRODUCIDO 29.02.12	
	Q162040000	TUERCA EXAGONAL M6	HEXAGONAL NUT M6	2	2	2	2	2	2			
	Q262040000	ARANDELA GROW. A6 A.304	WASHER GROW. A6 A.304	2	2	2	2	2	2			
16	P443060000	TAPON	STOPPER	1	1	1	1	1	1			
	N503017000	SOPORTE TERMOSTATO 1001713	THERMOSTAT SUPPORT 1001713	1	1	1	1	1	1			
17	Z713038000	REGU. TERMOS. TANQUE 60 °C	THERM.TANQUE REGULATOR	1	1	1	1	1	1		ELIMINADO 30.11.2012	
17	12044848	REGULADOR 60°C Tc DE 85°C	REGULATOR 60°C Tc DE 85°C	1	1	1	1	1	1		INTRODUCIDO 30.11.2012	
18	Z200313000	PERFIL GOMA ESPONJOSA	GOMA PROFILE	1	1	1	1	1	1			
19	Z202903000	PANEL LATERAL IZQUIERDO	LEFT SIDE PANEL	1	1		1	1	1			
19	Z212917000	PANEL LATERAL IZDO. DOBLE P.	LEFT SIDE PANEL			1						
S/Nº	Z202902000	PANEL LATERAL DERECHO	RIGHT SIDE PANEL	1	1		1	1	1			
S/Nº	Z212918000	PANEL LATERAL DCHO. DOBLE P.	RIGHT SIDE PANEL			1						
	Q152004000	TORNIL, APLASTADO M5x13 A304	FLAT HEADED BOLT M5x13 A304	4	4	4	4	4	4			
	Q221012000	TUERCA RAPIDA M,5	RAPID NUT M,5	2	2	2	2	2	2			
20	Z200107000	PATA REGULABLE	ADJUSTABLE LEG	4	4	4	4	4	4			
21	Z202921000	PANEL POSTERIOR INFERI. ALUM.	LOWER REAR PANEL ALUM.				1				ELIMINADO 02.05.2012	
21	12022495	PANEL POSTERIOR INFERI. B.T.	LOWER REAR PANEL B.T.				1				INTRODUCIDO 02.05.2012	
22	Z200341000	CAJA SOLDADA LJ. A.F. AD	WELDED BOX LJ. A.F. AD	1	1	1		1	1			
22	Z200343000	CAJA SOLDADA LJ. A.F. AD "D"	WELDED BOX LJ. A.F. AD "D"				1					
	Q162040000	TUERCA EXAGONAL M6	HEXAGONAL NUT M6	8	8	8	8	8	8			
	Q302022000	ARANDELA 16X6X1.2 A.304	WASHER 16X6X1.2 A.304	8	8	8	8	8	8			
23	Z202904000	PANEL POSTERIOR ALU.FI-30	REAR PANEL ALU.FI-30	1	1		1	1	1			
23	Z212920000	PANEL POSTER. DOBLE PARED	REAR PANEL ALU.FI-30			1						
	Q152004000	TORNIL, APLASTADO M5x13 A304	FLAT HEADED BOLT M5x13 A304	4	4	4	4	4	4			

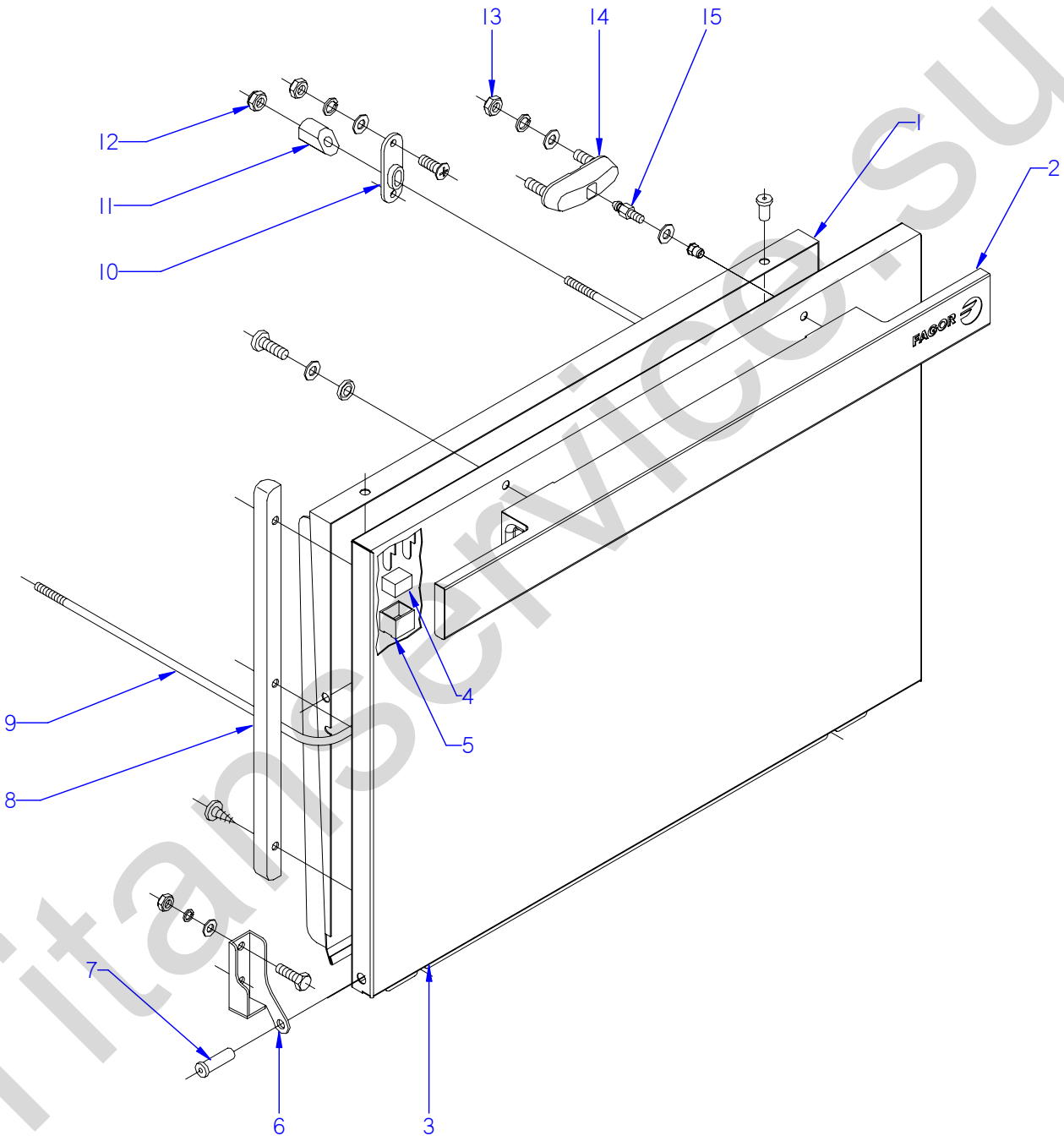

ITEM MARCADO EN COLOR = REPUESTO RECOMENDADO  
 COLOURED ITEM = RECOMMENDED SPARE PART

N plano C-2471	Firma <i>[Signature]</i>	Fecha 2009-12	Aparato LAVAVAJILLAS AD-64	Lamina 2	Fagor Industrial S. Coop. <b>FAGOR</b> Omate
			PUERTA		

MOD.		LAVAVAJILLAS DE APERTURA FRONTAL		ZONA	PUERTA						PLANO	C-2471
ITEM	CODIGO	DENOMINACION	TEXTO	AD-64	AD-64 B	AD-64 C	AD-64 D	AD-64 DD	AD-64 B DD		NOTAS	
	12091060	KIT PUERTA AD-48 / AD-64 AF	DOOR AD-48 / AD-64 AF KIT	1	1	1	1	1	1			
1	Z200556000	CONTRAPUERTA COMPLETA	COMPL. DOOR REVERSE	1	1	1	1	1	1			
	Q412000000	REMACHE TUBULAR 4 x 8	TUBULAR RIVET 4 x 8	4	4	4	4	4	4			
	Q162030000	TUERCA EXAGONAL M5	HEXAGONAL NUT M5	2	2	2	2	2	2			
2	Z200558000	ASA FI 30	HANDLE FI30	1	1		1	1	1		ELIMINADO 31.03.10	
2	Z200565000	ASA AD-48	HANDLE FI30	1	1		1	1	1		INTRODUCIDO 31.03.10	
2	Z210501000	ASA AD-48 C	HANDLE AD-48 C			1					ELIMINADO 31.03.10	
2	Z210502000	ASA AD-48 C	HANDLE AD-48 C			1					INTRODUCIDO 31.03.10	
S/Nº	Z200564000	TACO SUJECCION	FASTENING RAWL	2	2	2	2	2	2		ELIMINADO 15.02.11	
S/Nº	Z210503000	TACO SUJECCION	FASTENING RAWL	2	2	2	2	2	2		INTRODUC. 15.02.11	
3	Z200561000	PUERTA COMPLETA AD	COMPLETE DOOR AD	1	1	1	1	1	1			
S/Nº	Z206135000	CHECK LIST LAVAVAJILLAS FAGOR	CHECK LIST	1	1	1	1	1	1		INTRODUCIDO 19.07.10	
4	Z200506000	IMAN	MAGNET	1	1	1	1	1	1			
5	Z200507000	PROTECTOR IMAN	MAGNET PROTECTOR	1	1	1	1	1	1			
6	Z400514000	BISAGRA IZQUIERDA T-C.	LEFT HINGE T-C.	1	1	1	1	1	1			
S/Nº	Z400515000	BISAGRA DERECHA T-C.	RIGHT HINGE T-C.	1	1	1	1	1	1			
	Q012042000	TORNILLO EXAGONAL M6X15	HEXAGONAL BOLT M6x15	4	4	4	4	4	4			
	Q262040000	ARANDELAS GROW. A6 A.304	WASHER GROW. A6 A.304	4	4	4	4	4	4			
	Q162040000	TUERCA EXAGONAL M6	HEXAGONAL NUT M6	4	4	4	4	4	4			
7	Z400516000	EJE PUERTA	DOOR SHAFT	2	2	2	2	2	2			
8	Z200524000	MARCO PUERTA	DOOR FRAME	2	2	2	2	2	2			
	Q412000000	REMACHE TUBULAR 4 x 8	TUBULAR RIVET 4 x 8	6	6	6	6	6	6			
9	Z200555000	VARILLA TENSOR	TIGHTENER ROD	1	1	1	1	1	1			
10	Z200310000	SOPORTE TENSOR	TIGHTENER SUPPOR	2	2	2	2	2	2			
	Q152004000	TORNIL, APLASTADO M5x13 A304	FLAT HEADED BOLT M5x13 A304	4	4	4	4	4	4			
	Q162030000	TUERCA EXAGONAL M5	HEXAGONAL NUT M5	4	4	4	4	4	4			
11	Z200522000	TENSOR PUERTA	TIGHTENER DOOR	2	2	2	2	2	2			
12	Q222012000	TUERCA AUTOB. M6	SELF-LOCKING NUT M6	2	2	2	2	2	2			
13	Q222012000	TUERCA AUTOB. M6	SELF-LOCKING NUT M6	4	4	4	4	4	4			
14	Z200607000	CONJUNTO CIERRE PUER.T-CO	LOCK UNIT PUERTAT-CO	2	2	2	2	2	2			
15	Z200601000	ENGANCHE CIERRE	LOCK LATCH	2	2	2	2	2	2			

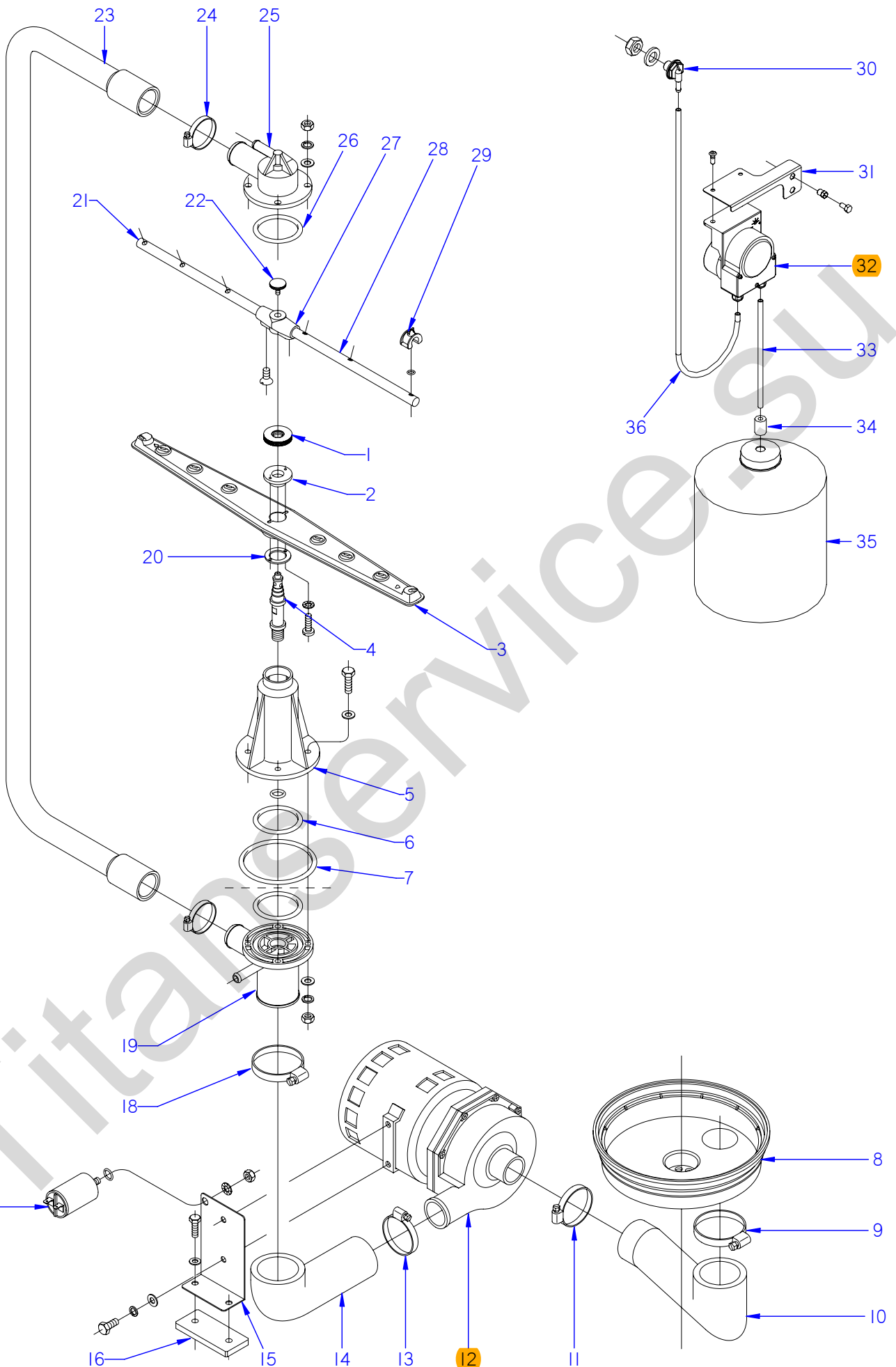

ITEM MARCADO EN COLOR = REPUESTO RECOMENDADO  
 COLOURED ITEM = RECOMMENDED SPARE PART

N plano	Firma	Fecha	Aparato	CONJUNTO FUNCIONAL DE LAVADO	Lamina	Fagor Industrial S.Coop. <b>FAGOR</b>
C-2472	<i>(Signature)</i>	2009-12	LAVAVAJILLAS AD-64		3	Oñate

MOD.		LAVAVAJILLAS DE APERTURA FRONTAL		ZONA	CONJUNTO FUNCIONAL DE LAVADO					PLANO	C-2472
ITEM	CODIGO	DENOMINACION	TEXTO	AD-64	AD-64 B	AD-64 C	AD-64 D	AD-64 DD	AD-64 B DD		NOTAS
1	Z200705000	TUERCA ESPECIAL M.14X1	SPECIAL NUT M.14X1	2	2	2	2	2	2		
2	Z650704000	ENGANCHE DISTRIBUIDOR	DISTRIBUTOR CATCH	2	2	2	2	2	2		ELIMINADO 11.02.2013
2	12045103	ENGANCHE DISTRIBUIDOR	DISTRIBUTOR CATCH	2	2	2	2	2	2		INTRODUCIDO 11.02.2013
3	Z650716000	DISTRIBUIDOR MONTADO	DISTRIBUTOR	2	2	2	2	2	2		
4	Z200704000	EJE CENTRAL	CENTRAL SHAFT	2	2	2	2	2	2		
5	Z200701000	SOPORTE DISTRIBUID. INFERIOR	LOWER DISTRIB. SUPPORT	1	1	1	1	1	1		
	Q307050000	JUNTA TOR.13.94X19.18X2.6	O-RING 13.94X19.18X2.6	1	1	1	1	1	1		
6	Q307052000	JUNTA TOR.50.17X60.83X5.3	O-RING 50.17X60.83X5.3	2	2	2	2	2	2		
7	Q307049000	JUNTA TOR.85.09X95.75X5.3	O-RING 85.09X95.75X5.3	1	1	1	1	1	1		
8	Z200906000	CUBETA	TRAY	1	1	1	1	1	1		
9	Q881324000	ABRAZADERA 50-70L	CLAMP 50-70L	1	1	1	1	1	1		
10	Z200904000	CODO ASPIRACION 1003018	EXTRACTOR ELBOW	1	1	1	1	1	1		
11	Q881324000	ABRAZADERA 50-70L	CLAMP 50-70L	1	1	1	1	1	1		
12	Z201011000	BOMBA DE LAVADO	WASH PUMP	1	1	1	1	1	1		
	Z201082000	TURBINA PARA 50 HZ.88 MM	TURBINE 50 HZ.88 MM	1	1	1	1	1	1		
	Z201081000	CONJUNTO JUNTA Y RETEN	JOINT BOARD AND SEAL	1	1	1	1	1	1		
12	Z203511000	BOMBA DE LAVADO 60 HZ.	WASH PUMP 60 HZ.	1	-	-	-	-	-		
	Z201083000	TURBINA 60 HZ.78 MM	TURBINE 60 HZ.78 MM	1	-	-	-	-	-		
	Z201081000	CONJUNTO JUNTA Y RETEN	JOINT BOARD AND SEAL	1	-	-	-	-	-		
13	Q881307000	ABRAZADERA 40-60	CLAMP 40-60	1	1	1	1	1	1		
14	Z200905000	CODO IMPULSION 1003017	IMPULSE ELBOW 1003017	1	1	1	1	1	1		
15	Z201002000	SOPORTE MOTOBO.F-3-4-5-6	MOTOR PUMP SUPPORT	1	1	1	1	1	1		
	Q012041000	TORNIL. EXAGONAL M6X10 A.304	HEX BOLT M6X10 A.304	2	2	2	2	2	2		
16	Z201003000	BASE BOMBA LAVADO 1003016	WASH PUMP BASE	1	1	1	1	1	1		
	Q012033000	TORNIL. EXAGONAL M5X20 A.304	HEX BOLT M5X20 A.304	2	2	2	2	2	2		
	Q232030000	ARANDELA A5	FAN WASHER A5	2	2	2	2	2	2		
17	V321300000	CONDENSADOR 10 M.F.	CONDENSER 10 M.F.	1	1	1	1	1	1		
	Q307048000	JUNTA TORICA 9.12X16.18X3.53	O-RING 9.12X16.18X3.53	1	1	1	1	1	1		
	Q162050000	TUERCA EXAGONAL M8x1 INOX.	HEXAGONAL NUT M8x1 INOX.	1	1	1	1	1	1		
	Q261050000	ARANDELA MUELLE A8	SPRING WASHER A8	1	1	1	1	1	1		
18	Q881324000	ABRAZADERA 50-70L	CLAMP 50-70L	1	1	1	1	1	1		



MOD.		LAVAVAJILLAS DE APERTURA FRONTAL		ZONA	CONJUNTO FUNCIONAL DE LAVADO					PLANO	C-2472
ITEM	CODIGO	DENOMINACION	TEXTO	AD-64	AD-64 B	AD-64 C	AD-64 D	AD-64 DD	AD-64 B DD		NOTAS
19	Z200703000	PASAMUROS	WALL BUSHING	1	1	1	1	1	1		
	Q232040000	ARANDELA A6	WASHER A6	4	4	4	4	4	4		
	Q262040000	ARANDELA GROW. A6 A.304	WASHER GROW. A6 A.304	4	4	4	4	4	4		
	Q162040000	TUERCA EXAGONAL M6	HEXAGONAL NUT M6	4	4	4	4	4	4		
20	Z650711000	AMARRE ENGANCHE DISTRIBUID.	DISTRIBUT. CATCH FASTENING	2	2	2	2	2	2		
	Q152015000	TORNILLO ALOMADO M3X6	CURVED SCREW M3X6	4	4	4	4	4	4		
	Q242010000	ARANDELA ABANICO A.3 A304	FAN WASHER A.3 A304	4	4	4	4	4	4		
21	Z201902000	RAMA DE ACLARADO IZQUIERDA	LEF TRINSE BRANCH	2	2	2	2	2	2		
22	Q152016000	TORNILLO ESPECIAL M.5X0.8	SPECIAL BOLT M.5X0.8	2	2	2	2	2	2		
23	Z200706000	ARBOL DE LAVADO	WASH CAM	1	1	1	1	1	1		
24	Q881305000	ABRAZADERA 25-40	CLAMP 25-40	2	2	2	2	2	2		
25	Z200707000	SOPORTE DISTRIBUIDOR SUPER.	UPPER DISTRIB. SUPPORT	1	1	1	1	1	1		
	Q232040000	ARANDELA A6	WASHER A6	4	4	4	4	4	4		
	Q262040000	ARANDELA GROW. A6 A.304	WASHER GROW. A6 A.304	4	4	4	4	4	4		
	Q162040000	TUERCA EXAGONAL M6	HEXAGONAL NUT M6	4	4	4	4	4	4		
26	Q307052000	JUNTA TOR.50.17X60.83X5.3	O-RING 50.17X60.83X5.3	1	1	1	1	1	1		
27	Z201903000	SOPORTE RAMAS ACLARADO	TRINSE BRANCH SUPPORT	2	2	2	2	2	2		
	Q042021000	TORN. AVELLANADO M4X10 A.304	COUNTERSUNK BOLT M4X10 A3	4	4	4	4	4	4		
28	Z201901000	RAMA DE ACLARADO DERECHA	RIGHT TRINSE BRANCH	2	2	2	2	2	2		
29	Z211903000	TOBERA ACLARADO	RINSE NOZZLE	12	12	12	12	12	12		
30	Z230905000	PASAMUROS DETERGENTE	INOX DETERG INOX I INOX I INOX	-	-	1	-	1	1		ELIMINADO 30.11.10
30	Z208927000	PASAMUROS DETERGENTE INOX	DETERGENT I DETER DETER DETER	-	-	1	-	1	1		INTRODUCIDO 30.11.10
31	Z208434000	SOPORTE DOSIFICADOR W	DOSEFOR W SUPPORT	-	-	1	-	1	1		
	Q411304000	REMACHE AVIBULB Ø4,8	AVIBULB Ø4,8 RIVET	-	-	2	-	2	2		
	Q012031000	TORNIL. EXAGONAL M5X10 A.304	HEXAGONAL BOLT M5X10	-	-	2	-	2	2		
32	Z208903000	DOSIFIC. DGTE REGULABLE G300	DOSEFOR DETERGENT	-	-	1	-	1	1		
33	Z448614000	CONDUCTO ASPIRACIÓN	CONDUIT	-	-	1	-	1	1		
34	Z701152000	PESO FILTRO	FILTER WEIGHT	-	-	1	-	1	1		
35	-	GARRAFA DETERGENTE	DETERGENT CAN	-	-	1	-	1	1		
36	3699300000	CONDUCTO DOSIFICA FOR TRANS.	CONDUIT	-	-	1	-	1	1		
S/Nº	Z208904000	CABLEADO DOSIFICADOR DTGTE	WIRE FEEDER DETERGENT	-	-	1	-	1	1		INTRODUCIDO 01.12.10

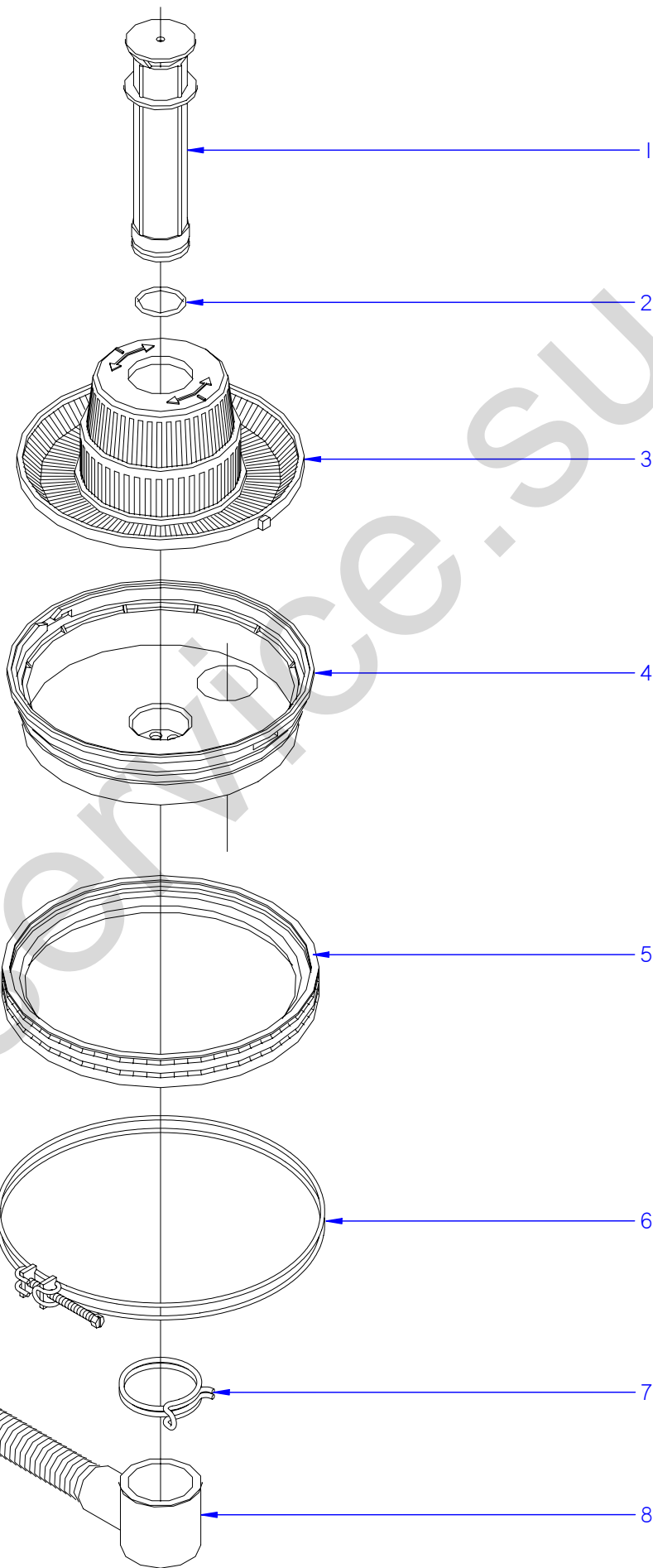

ITEM MARCADO EN COLOR = REPUESTO RECOMENDADO  
 COLOURED ITEM = RECOMMENDED SPARE PART

N plano	Firma	Fecha	Aparato	CONJUNTO FUNCIONAL DESAGUE	Lamina	Fagor Industrial S.Coop. <b>FAGOR</b>
C-2473	<i>(Signature)</i>	2009-12	LAVAVAJILLAS	AD-64 / 64D / 64DD	4	Oñate



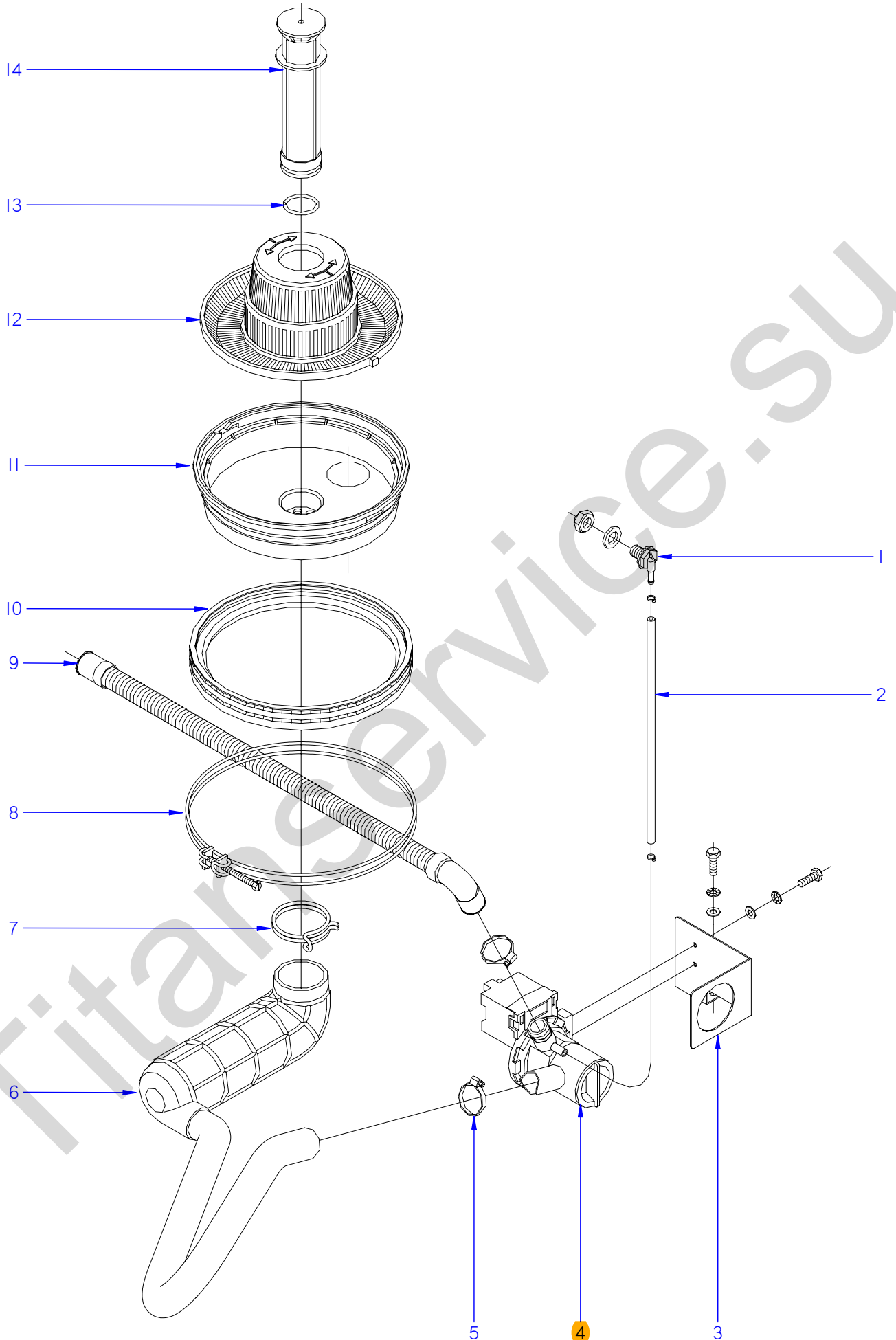

ITEM MARCADO EN COLOR = REPUESTO RECOMENDADO  
 COLOURED ITEM = RECOMMENDED SPARE PART

N plano	Firma	Fecha	Aparato	CONJUNTO FUNCIONAL DESAGUE	Lamina	Fagor Industrial S.Coop. <b>FAGOR</b>
C-2474	<i>[Signature]</i>	2009-12	LAVAVAJIL. AD-64 B / C / B DD		5	Oñate

MOD.		LAVAVAJILLAS DE APERTURA FRONTAL		ZONA	CONJUNTO FUNCIONAL DESAGÜE			PLANO	C-2474
ITEM	CODIGO	DENOMINACION	TEXTO	AD-64 B	AD-64 C	AD-64 B DD			NOTAS
1	Z230905000	PASAMUROS DETERGENTE	INOX DETERGENT WALL BUSHIN	1	1	1			
	Q306024000	JUNTA Ø18X12.5X1.5	SEAL 18X12.5X1.5	1	1	1			ELIMINADO 25.06.2012
	12010191	JUNTA 14X24X3	SEAL 14X24X3	1	1	1			INTRODUCIDO 25.06.2012
	Q162070000	TUERCA EXAGONAL M12	HEXAGONAL NUT M12	1	1	1			
2	3702400000	TUBO GOMA NEGRO Ø 8*4	BLACK RUBBER PIPE Ø 8*4	1	1	1			
	P102154000	BRIDA ELASTICA TUBO	ELASTIC PIPE FLANGE	2	2	2			
3	Z220904000	SOPORTE BOMBA DESAGUE	DRAINAGE PUMP SUPPORT	1	1	1			
	Q012031000	TORNIL.EXAGONAL M5X10 A.304	HEXAGONAL BOLT M5x10	4	4	4			
	Q242030000	ARAND.ABAN. A5 A.304	FAN WASHER A5 A.304	4	4	4			
	Q232030000	ARANDELA A5	WASHER A5	4	4	4			
	Q232040000	ARANDELA A6	WASHER A6	2	2	2			
4	Z220901000	BOMBA DESAGUE 30W	DRAINAGE PUMP 30W	1	1	1			
4	Z223501000	BOMBA DESAGUE 30W 60HZ	DRAINAGE PUMP 30W 60HZ	1	1	1			
5	Q881305000	ABRAZADERA 25-40	CLAMP 25-40	2	2	2			
6	Z220902000	ACUMULADOR 1503019	ACCUMULATOR 1503019	1	1	1			
7	Q901308000	ABRAZAD. ELAST. 56-58.8	ELASTIC CLAMP 56-58.8	1	1	1			
8	Z200908000	ABRAZADERA CUBETA COMPL.	TRAY CLAMP	1	1	1			
9	Z220903000	MANGUERA DESAGUE	DRAINAGE HOSE	1	1	1			
10	Z200907000	JUNTA CUBETA	TRAY SEAL	1	1	1			
11	Z200906000	CUBETA	TRAY	1	1	1			
12	Z200922000	CONJUNTO FILTRO AF.	FILTER	1	1	1			
13	Q307051000	JUNTA TOR.36.17X41.41X2.6	O-RING 36.17X41.41X2.6	1	1	1			
14	Z200909000	ALIVIADERO	OVERFLOW	1	1	1			ELIMINADO 24.06.2013
14	12049258	ALIVIADERO AF MODELO B	OVERFLOW AF MOD. B	1	1	1			INTRODUCIDO 24.06.2013

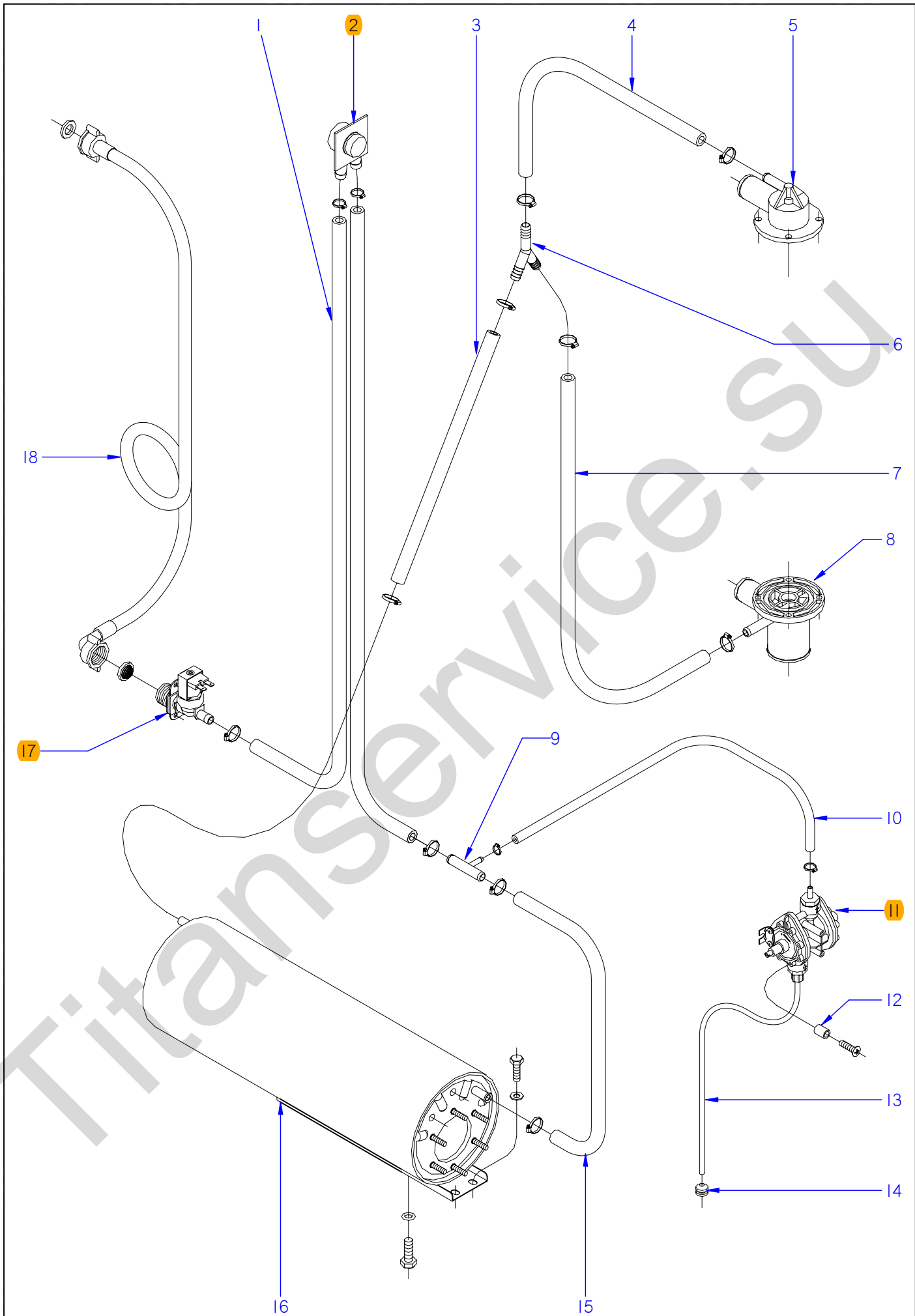

ITEM MARCADO EN COLOR = REPUESTO RECOMENDADO  
 COLOURED ITEM = RECOMMENDED SPARE PART

N plano	Firma	Fecha	Aparato	CONJUNTO FUNCIONAL ACLARADO	Lamina	Fagor Industrial S.Coop. <b>FAGOR</b>
C-2475	<i>[Signature]</i>	2009-12	LAVAVAJILLAS AD-64		6	Oñate

MOD.		LAVAVAJILLAS DE APERTURA FRONTAL		ZONA	CONJUNTO FUNCIONAL ACLARADO					PLANO	C-2475
ITEM	CODIGO	DENOMINACION	TEXTO	AD-64	AD-64 B	AD-64 C	AD-64 D	AD-64 B DD			NOTAS
1	3676900000	TUBO GOMA NEGRA Ø 17*10	BLACK RUBBER PIPE Ø17*10	2	2	2	2	2			
	Q881302000	ABRAZADERA 12-20	CLAMP 12/20	4	4	4	4	4			
2	Z231106000	VALVULA ANTIRRETORNO	NON-RETURN VALVE	1	1	1	1	1			
	Q881302000	ABRAZADERA 12/20	CLAMP 12/20	2	2	2	2	2			
3	3676900000	TUBO GOMA NEGRA Ø 17*10	BLACK RUBBER PIPE Ø17*10	1	1	1	1	1			
	Q881302000	ABRAZADERA 12-20	CLAMP 12/20	2	2	2	2	2			
4	3676900000	TUBO GOMA NEGRA Ø 17*10	BLACK RUBBER PIPE Ø17*10	1	1	1	1	1			
	Q881302000	ABRAZADERA 12-20	CLAMP 12/20	2	2	2	2	2			
5	Z200707000	SOPORTE DISTRIB. SUPERIOR	UPPER DISTRIB. SUPPORT	1	1	1	1	1			
6	Z201106000	RACORD EN Y	Y CONNECTION	1	1	1	1	1			
7	3676900000	TUBO GOMA NEGRA Ø 17*10	BLACK RUBBER PIPE Ø17*10	1	1	1	1	1			
	Q881302000	ABRAZADERA 12-20	CLAMP 12/20	1	1	1	1	1			
8	Z200703000	PASAMUROS	WALL BUSHING	1	1	1	1	1			
	Q881302000	ABRAZADERA 12-20	CLAMP 12/20	1	1	1	1	1			
9	Z601157000	TOMA PRESION	PRESSURE INTAKE	1	1	1	1	1			
10	3704000000	TUBO GOMA NEGRO Ø 10,5*5	BLACK RUBBER PIPE Ø 10,5*5	1	1	1	1	1			
	Q881308000	ABRAZADERA 8-14L	CLAMP 8-14L	2	2	2	2	2			
11	Z211109000	DOSIFICADOR TENSOACTIVO N-6	SURFACE ACT. DISP. N-6	1	1	1	1	1			ELIMINADO 18.06.2012
11	12045206	DOSIFICADOR_ABRILLANTADOR_A	RINSE AID DISPENSER	1	1	1	1	1			INTRODUCIDO 18.06.2012
12	Z203007000	CASQUILLO	CASE	2	2	2	2	2			
	Q041324000	TORN. AVELLA. M4x25 H.ZINCADO	COUNTERSUNK BOLT M4x25	2	2	2	2	2			
13	Z448618000	CONDUCTO ABRILLANTADOR	POLISH DUCT	1	1	1	1	1			
14	Z701152000	PESO FILTRO	FILTER WEIGHT	1	1	1	1	1			
15	3676900000	TUBO GOMA NEGRA Ø 17*10	BLACK RUBBER PIPE Ø17*10	1	1	1	1	1			
	Q881302000	ABRAZADERA 12-20	CLAMP 12/20	2	2	2	2	2			
16	12022943	CALDERIN COMPLETO	COMPL. BOILER	1	1	1	1	1			
	Q012063000	TORNIL. EXAGONAL M10x20 A.304	HEXAGONAL BOLT M10x20 A304	1	1	1	1	1			
	Q307048000	JUNTA TORICA Ø9.12X16.18X3.53	O-RING Ø9.12X16.18X3.53	1	1	1	1	1			
	Q012031000	TORNIL. EXAGONAL M5x10 A.304	HEXAGONAL BOLT M5x10 A.304	2	2	2	2	2			
	Q232030000	ARANDELA A5	WASHER A5	2	2	2	2	2			







MOD.		LAVAVAJILLAS DE APERTURA FRONTAL		ZONA	CONJUNTO FUNCIONAL ACLARADO				PLANO	C-2476
ITEM	CODIGO	DENOMINACION	TEXTO	AD-64 D					NOTAS	
1	Z602121000	MANGUERA ENTRADA AGUA	WATER INTAKE HOSE	1						
2	P255001000	ELECTROVALVULA DOBLE	DOUBLE SOLENOID VALVE	1						
	P305013000	REGULADOR 1L. AMA 255.005	REGULATOR 1L. AMA 255.005	1						
	Q152024000	TORN. AVELLANADO M4x8 A.304	COUNTERSUNK BOLT M4x8	2						
3	3676900000	TUBO GOMA NEGRA Ø 17*10	BLACK RUBBER PIPE Ø17*10	2						
	Q881302000	ABRAZADERA 12-20	CLAMP 12/20	4						
4	3676900000	TUBO GOMA NEGRA Ø 17*10	BLACK RUBBER PIPE Ø17*10	2						
	Q881302000	ABRAZADERA 12-20	CLAMP 12/20	4						
5	3676900000	TUBO GOMA NEGRA Ø 17*10	BLACK RUBBER PIPE Ø17*10	1						
	Q881302000	ABRAZADERA 12-20	CLAMP 12/20	2						
6	Z200707000	SOPORTE DISTRIB. SUPERIOR	UPPER DISTRIB. SUPPORT	1						
7	Z201106000	RACORD EN Y	Y CONNECTION	1						
8	3676900000	TUBO GOMA NEGRA Ø 17*10	BLACK RUBBER PIPE Ø17*10	1						
	Q881302000	ABRAZADERA 12-20	CLAMP 12/20	2						
9	Z200703000	PASAMUROS	WALL BUSHING	1						
10	Z601157000	TOMA PRESION	PRESSURE INTAKE	1						
11	3704000000	TUBO GOMA NEGRO Ø 10,5*5	BLACK RUBBER PIPE Ø 10,5*5	1						
	Q881308000	ABRAZADERA 8-14L	CLAMP 8-14L	2						
12	Z211109000	DOSIFICADOR TENSOACTIVO N-6	SURFACE ACT. DISP. N-6	1						
13	Z203007000	CASQUILLO	CASE	2						
	Q041324000	TORN. AVELLA. M4x25 H.ZINCADO	COUNTERSUNK BOLT M4x25	2						
14	Z448618000	CONDUCTO ABRILLANTADOR	POLISH DUCT	1						
15	Z701152000	PESO FILTRO	FILTER WEIGHT	1						
16	3676900000	TUBO GOMA NEGRA Ø 17*10	BLACK RUBBER PIPE Ø17*10	1						
	Q881302000	ABRAZADERA 12-20	CLAMP 12/20	2						
17	12022943	CALDERIN COMPLETO	COMPL. BOILER	1						
	Q012063000	TORNIL. EXAGONAL M10x20 A.304	HEXAGONAL BOLT M10x20 A304	1						
	Q307048000	JUNTA TORICA Ø9.12X16.18X3.53	O-RING Ø9.12X16.18X3.53	1						
	Q012031000	TORNIL. EXAGONAL M5x10 A.304	HEXAGONAL BOLT M5x10 A.304	2						
	Q232030000	ARANDELA A5	WASHER A5	2						



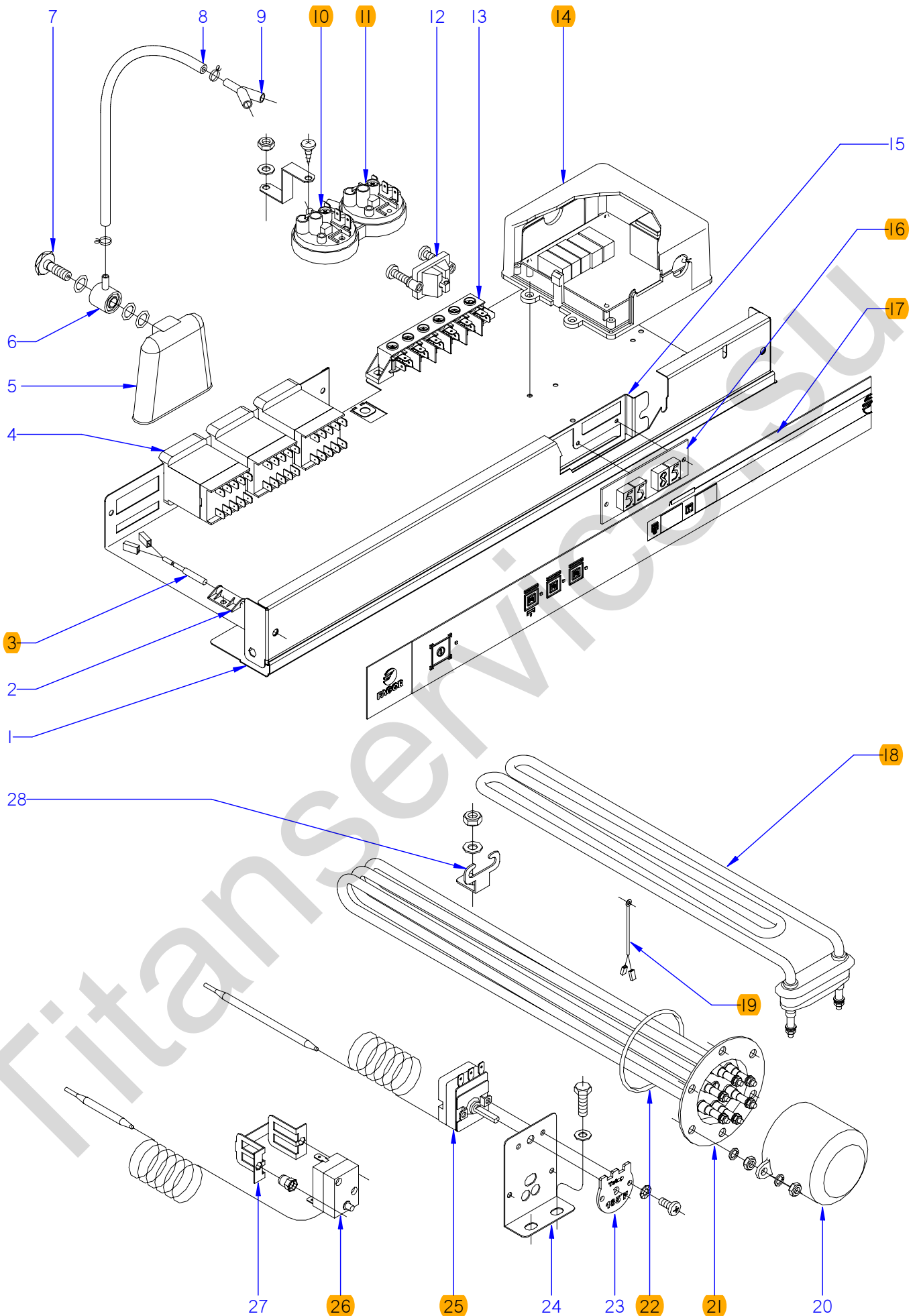

ITEM MARCADO EN COLOR = REPUESTO RECOMENDADO  
 COLOURED ITEM = RECOMMENDED SPARE PART

N plano	Firma	Fecha	Aparato	CONJUNTO FUNCIONAL ELECTRICO	Lamina	Fagor Industrial S.Coop. <b>FAGOR</b>
C-2477	<i>(Signature)</i>	2009-12	LAVAVAJILLAS AD-64		8	Oñate

MOD.		LAVAVAJILLAS DE APERTURA FRONTAL		ZONA	CONJUNTO FUNCIONAL ELECTRICO					PLANO	C-2477
ITEM	CODIGO	DENOMINACION	TEXTO	AD-64	AD-64 B	AD-64 C	AD-64 D	AD-64 DD	AD-64 B DD		NOTAS
1	Z202930000	FRENTE COMPLETO AD	COMPLETE FRONT AD	1	1	1	1	1	1		
2	Z203010000	AMARRE INTERRUPT. MAGNETICO	MAGNETIC SWITCH FASTENER	1	1	1	1	1	1		
	Q152004000	TORNILLO APLASTADO M5x13 A304	FLAT HEADED BOLT M5x13 A304	1	1	1	1	1	1		
	Q162030000	TUERCA EXAGONAL M5	HEXAGONAL NUT M5	1	1	1	1	1	1		
3	Z203009000	INTERRUPTOR MAGNETICO	MAGNETIC SWITCH	1	1	1	1	1	1		
4	Z213007000	CONTACTOR 230 V. 50-60 HZ	CONTACTOR 230 V. 50-60 HZ	4	4	4	4	4	4		
4	Z213007000	CONTACTOR 230 V. 50-60 HZ	CONTACTOR 230 V. 50-60 HZ	1	1	1	1	1	1		ELIMINADO 14.05.10
4	Z213007000	CONTACTOR 230 V. 50-60 HZ	CONTACTOR 230 V. 50-60 HZ	1	1	1	1	1	1		INTRODUCIDO 01.06.11
4	Z683087000	CONTACTOR 3TF20 01-3AL2 230	CONTACTOR 3TF20 01-3AL2	1	1	1	1	1	1		INTRODUCIDO 14.05.10
4	Z683087000	CONTACTOR 3TF20 01-3AL2 230	CONTACTOR 3TF20 01-3AL2	1		1	1				ELIMINADO 01.06.11
5	Z203011000	CAMARA PRESOSTATO	PRESSURE SWITCH	1	1	1	1	1	1		
6	Z203012000	EMPALME PRESOSTATO	PRESSURE SWITCH CONNEX	1	1	1	1	1	1		
7	Z203013000	TORNILLO PRESOSTATO	PRESSURE SWITCH BOLT	1	1	1	1	1	1		
	Q307003000	JUNTA TORICA 16.01X10.77X2.62	O-RING 16.01X10.77X2.62	3	3	3	3	3	3		
8	3702400000	TUBO GOMA NEGRO D 8*4	BLACK RUBBER PIPE Ø 8*4	1	1	1	1	1	1		
	P102154000	BRIDA ELASTICA TUBO	ELASTIC PIPE FLANGE	2	2	2	2	2	2		
9	Z103077000	RACORD EN Y	Y CONNECTION		1	1			1		
10	Z203023000	PRESOSTATO SIMPLE PVS	SIMPLE PRESSURE SWITCH	1	1	1	1	1	1		
11	Z223005000	PRESOSTATO SIMPLE P.V.S.	SIMPLE PRESSURE SWITCH		1	1			1		
S/Nº	Z218002000	ESCUADRA AMARRE PRESOSTATO	PRESSURE SWITCH SQUARE		1	1			1		
	Q082032000	TORNILLO ALOMADO BZ-3,5X9,5	ALOM. BOLT BZ-3,5X9,5	1	1	1	1	1	1		
	Q152004000	TORNILLO APLASTADO M5x13 A304	FLAT HEADED BOLT M5x13 A304	1	1	1	1	1	1		
	Q232030000	ARANDELA A5	WASHER A5	1	1	1	1	1	1		
	Q162030000	TUERCA EXAGONAL M5	HEXAGONAL NUT M5	1	1	1	1	1	1		
12	Z203020000	RETENEDOR DE CABLE	CABLE HOLDER	1	1	1	1	1	1		
13	R253044000	REGLETA AUXILIAR FV-122	AUXILIARY STRIP FV-122	1	1	1	1	1	1		
	Z213005000	ROTULO ADHESIVO	ADHES. LABEL	1	1	1	1	1	1		
	Q152004000	TORNILLO APLASTADO M5x13	FLAT HEADED BOLT M5x13 A304	2	2	2	2	2	2		
	Q232030000	ARANDELA A5	WASHER A5	2	2	2	2	2	2		
	Q162030000	TUERCA EXAGONAL M5	HEXAGONAL NUT M5	2	2	2	2	2	2		
S/Nº	12045569	BORNAS PORTAFUSIB. 13A 2,5	FUSE HOLDER TERMINAL 13A	1	1	1	1	1	1		INTRODUCIDO 14.05.10

MOD.		LAVAVAJILLAS DE APERTURA FRONTAL		ZONA	CONJUNTO FUNCIONAL ELECTRICO					PLANO	C-2477
ITEM	CODIGO	DENOMINACION	TEXTO	AD-64	AD-64 B	AD-64 C	AD-64 D	AD-64 DD	AD-64 B DD		NOTAS
14	Z213069000	TARJETA 5 RELES GICAR	CHAMBER 5 RELAY GICAR	1	1	1	1	1	1		ELIMINADO 01.06.11
14	Z213073000	TARJETA 5 RELES	CHAMBER 5 RELAY	1	1	1	1	1	1		ELIMINADO 27.01.2013
14	12048170	TARJETA 5 RELES	CHAMBER 5 RELAY	1	1	1	1	1	1		ELIMINADO 02.09.2013
14	12008750	TARJETA 5 RELES	CHAMBER 5 RELAY	1	1	1	1	1	1		INTRODUCIDO 02.09.2013
	Q242020000	ARANDELA ABANICO A5 A.304	FAN WASHER A4 A.304	4	4	4	4	4	4		
	Q042022000	TORN. AVELLANADO M4X15	COUNTERSUNK BOLT M4X15	4	4	4	4	4	4		
15	Z203088000	SOPORTE COMPONENTES	COMPON. SUPPORT	1	1	1	1	1	1		
15	Z218432000	SOPORTE DISPLAY T <sup>a</sup> ADVANCE	DISPLAY T <sup>a</sup> ADV. SUPPORT	-	-	-	-	-	-		
	Q262030000	ARANDELA GROW. A5 A.304	WASHER GROW. A5 A.304	2	2	2	2	2	2		
	Q162030000	TUERCA EXAGONAL M5	HEXAGONAL NUT M5	2	2	2	2	2	2		
	R663036000	FIJACION CIRCUITO	CIRCUIT BINDINGS	3	3	3	3	3	3		ELIMINADO 29.10.10
16	Z713017000	DISPLAY GICAR TEMPERATURAS	DISPLAY GICAR	1	1	1	1	1	1		
16	Z218433000	DISPLAY T <sup>a</sup> ADVANCE W	DISPLAY T <sup>a</sup> ADVANCE W	-	-	-	-	-	-		
17	Z262908000	EMBELLECED. ADHESIVO AD-72	ADHES. TRIM AD-72	1	-	-	-	1	-		
17	Z222904000	EMBELLECED. ADHESIVO AD-48 C	ADHES. TRIM AD-48 C	-	1	1	-	-	1		
17	Z222906000	EMBELLECED. ADHESIVO AD-48 D	ADHES. TRIM AD-48 D	-	-	-	1	-	-		
17	Z218429000	EMBELLECED. ADHESIVO AD-64 CW	ADHES. TRIM AAD-64 CW	-	-	-	-	-	-		
18	Z203601000	RESISTENCIA TANQUE	TANK RESISTOR	1	1	1	1	1	1		
19	Z713028000	SONDA TEMPERATURA GICAR	TEMPERATURA PROBE GICAR	1	1	1	1	1	1		
19	Z268004000	SONDA TEMPERATURA GICAR	TEMPERATURA PROBE GICAR	-	-	-	-	-	-		
20	Z101723000	CAPERUZA RESISTENC. CALDERIN	BOILER RESIST. CAP	1	1	1	1	1	1		
	Q163140000	TUERCA EXAGONAL M6 LATON	HEXAGONAL NUT M6 BRASS	2	2	2	2	2	2		
	Q242030000	ARANDELA ABANICO A5 A.304	FAN WASHER A5 A.304	2	2	2	2	2	2		
	Q152004000	TORNILLO APLASTADO M5x13 A304	FLAT HEADED BOLT M5x13 A304	2	2	2	2	2	2		
21	Z241701000	RESISTENCIA CALDERIN	BOILER RESISTOR	1	1	1	1	1	1		
22	Q307035000	JUNTA TORICA AN-36 282333	"O" RING AN-36 282333	1	1	1	1	1	1		
23	Z718446000	CHAPA W 85°C	W 85°C PLATE	1	1	1	1	1	1		ELIMINADO 31.10.2012
24	Z203047000	SOPORTE TERMOSTATOS	THERMOSTAT SUPPORT	1	1	1	1	1	1		
	Q012031000	TORNIL. EXAGONAL M5X10 A.304	HEXAGONAL BOLT M5X10	2	2	2	2	2	2		
	Q232030000	ARANDELA A5	HEXAGONAL NUT M5	2	2	2	2	2	2		







AD 72, AD 72 W, AD 64, AD 64 AR+DD, AD 64 B, AD 64 BA, AD 64 B BT, AD 64 C, AD 64 D, AD 64 HY, AD 64 W

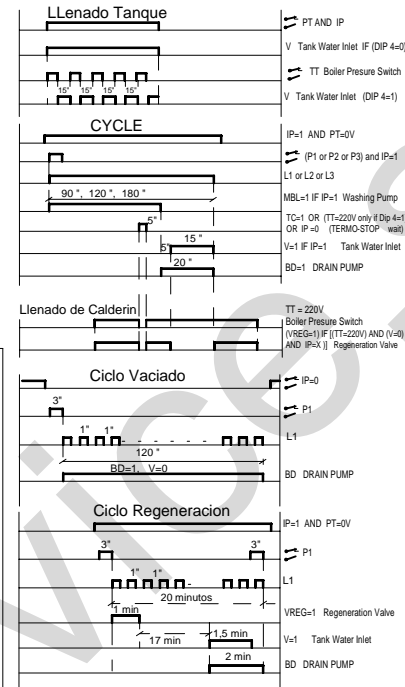
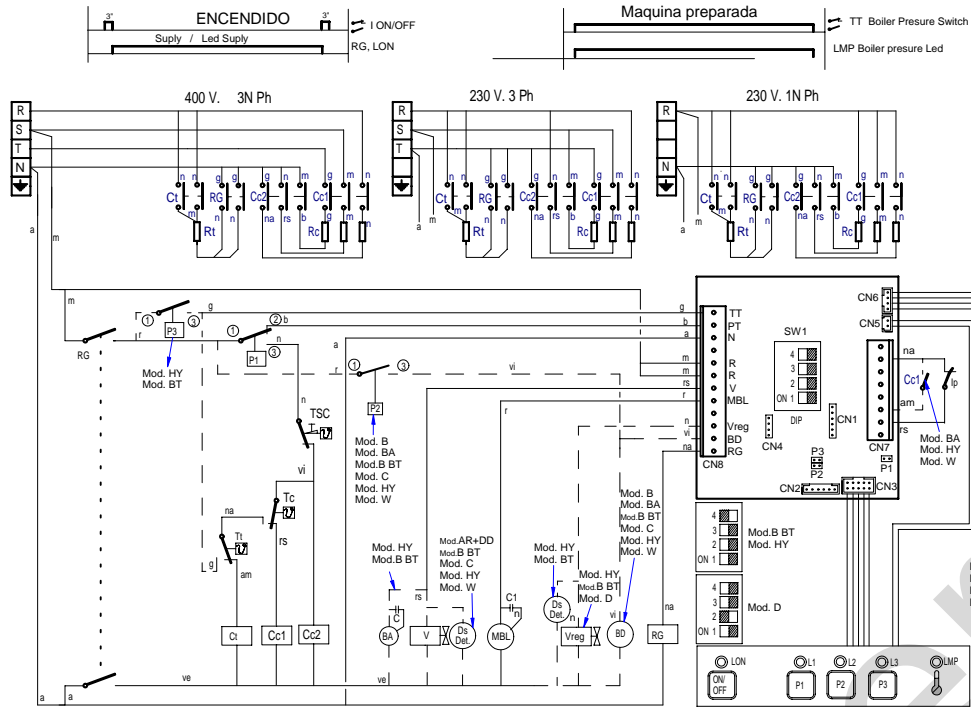

FAGOR ELECTRONICO MODELO ADVANCE	DIP1	DIP2	DIP3	DIP4	TIEMPOS CICLOS (sg.)
AD-48, AD-48 B, AD-48 DD, AD-48 B BT, AD-64, AD-64 B, AD-64 DD, AD-64 B BT, AD-72.	OFF	OFF	ON	OFF	P1=60 / P2= 90 / P3=180
AD-48 D, AD-64 D	OFF	ON	ON	OFF	
AD-48 C, AD-48 W, AD-48 HY, AD-64 C, AD-64 W, AD-64 HY, AD-72 W	OFF	OFF	ON	ON	

DIP1 = ON, al cerrar la puerta o bajar capó el lavavajillas se pone en marcha.  
 DIP1= OFF, al cerrar la puerta o bajar el capo el lavavajillas sigue lavando SÓLO SI EL CICLO NO HA ACABADO.

DIP2 = ON, Para los modelos que llevan DESCALCIFICADOR, versiones "D".  
 DIP2 = OFF, para los modelos con BOMBA DESAGÜE, versiones "B".

DIP1 + DIP3, con las diferentes combinaciones posibles configuramos los tiempos de ciclo.

DIP4 = ON, TERMOSTOP ACTIVADO, para los modelos con termo stop, versiones "C", "W" y "HY".  
 DIP4 = OFF, TERMOSTOP DESACTIVADO, para los modelos que NO llevan TERMOSTOP.

-	Esquema teorico L.A.F. AD 64	-	-	Z243052000	-	
Zk./Nº	Pieza	Cant.	Materiala/Material	Klas. zk/Nº Clas.	Gainazal akabera/Tratamiento	
Zk./Nº	Aldaketa/Modificaciones		Nork proposatua/Propuesta de	Data/Fecha	Perdoi orokorrak Tolerancias generales	
-	-	-	-	-	< 5 ± 0.2	
-	-	-	-	-	50 ÷ 100 ± 0.8	
-	-	-	-	-	5 ÷ 25 ± 0.4	
-	-	-	-	-	>100 ± 1	
-	-	-	-	-	25 ÷ 50 ± 0.6	
-	-	-	-	-	α ± 1	
	Sinadura/Firma	Data/Fecha	 Fagor Industrial, Koop. Elk. Mugatua		Gainazal perdoia Mecanizado superficial	
	Marraztua/Dibujado	M. Maillo 30-05-2009				-
	Proiektatua/Proyectado	M. Maillo 30-05-2009				-
	Egiatzatua/Comprobado	Z. Alube 30-05-2009				-
	Eskala/Escala		<b>LAVAVAJILLAS A.F.</b>		Plano Zk./Plano Nº HC-18216	
						-
	Plano hau ezin daiteke erabili, ez berritzatu, gure baimenik gabe.				Zk. gaitik ord.	



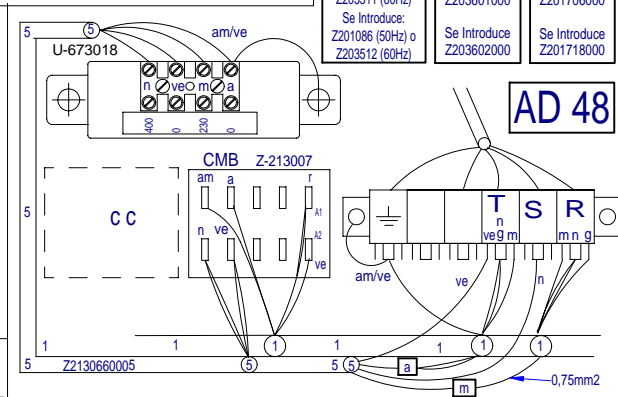
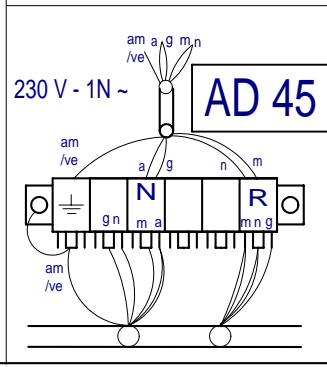
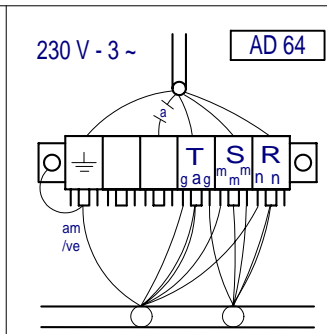
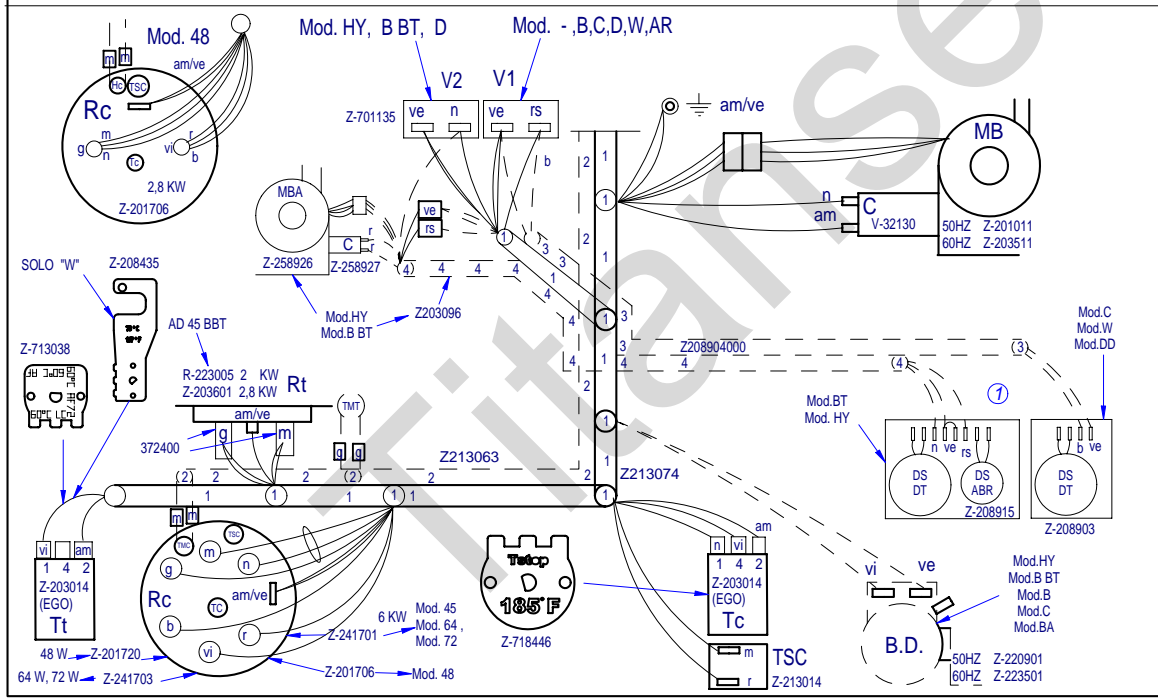
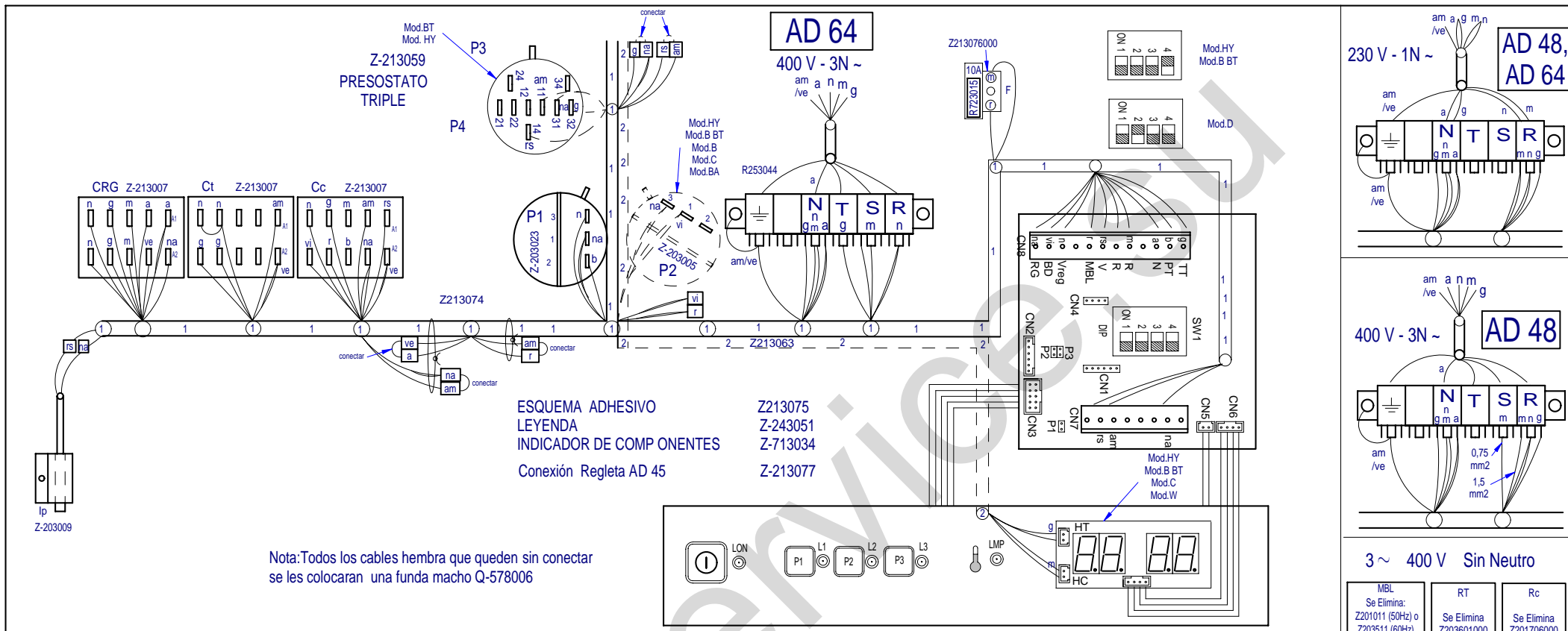

Plano montaje AD 48, AD 64. Gicar		Z203089000	
Nº Pieza	Material	Nº Clasificación	Acabado
Nº Modificación	Propuesta de	Fecha	Tolerancias generales
1	Actualizar dosificadores	M.Maillou	12-05-2011
		5-40s	50-40s
		25-40s	100s
			OK
Dibujado		Fecha	Mecanizado superficial
Proyectado		Fecha	
Comprobado		Fecha	
Escala		Fecha	
Firma			
M.Maillou			
Z-Atelier			
FAGOR			
LAVAVAJILLAS			Plano numero
			HC- 18210 - 1
			Sustituye el Nº
			Sustituye por

# LEYENDA APERTURA FRONTAL

	ESPAÑOL	FRANÇAIS	ENGLISH	DEUTSCH	ITALIANO
BD	Bomba desagüe	Pompe de vidange	Drain pump	Abflußpumpe	Pompa scarico
C 1/2/3	Condensador	Condensateur	Condenser	Kondensator	Condensatore
CMB	Contactador bomba lavado	Contacteur pompe lavage	Wash pump contactor	Kontaktschütz Waschpumpe	Contattore pompa lavaggio
Cc 1/2	Contactador calentamiento calderin	Contacteur chauff. surchauffeur	Boiler heating contactor	Kontaktschütz Boilerheizung	Contattore riscaldamento boiler
Ct	Contactador calentamiento tanque	Contacteur chauffage cuve	Tank heating contactor	Kontaktschütz Heizung Tank	Contattore riscaldamento serbatoio
CP	Rele puerta	Relais porte	Door relay	Türrelais	Rele porta
Ds.Det.	Dosificador detergente	Dosseur de detergent	Detergent doser	Dosierer Spülmittel	Dosatore detersivo
E.B	Electrobomba de presion	Electropompe de pression	Electric pressure pump	Elektro-Drucksteigerungspumpe	Electropompa pressione
IG	Interruptor general	Interrupteur general	Main switch	Hauptschalter	Interruttore generale
IP	Micro puerta	Micro porte	Door microswitch	Mikroschalter Tür	Micro porta
L1	Piloto de encendido	Voyant fonctionnement	Operation light	Betriebsanzeigelampe	Spia accensione
L2	Piloto marcha	Voyant demarrage	Start light	Startanzeigelampe	Spia avvio
L3	Piloto maquina preparada	Voyant machine prêt	Light machine ready	Betriebsbereitschaftsanzeigelampe	Pilota macchina preparata
MBL	Bomba lavado	Pompe lavage	Wash pump	Waschpumpe	Pompa lavaggio
M	Motor programador	Moteur du programmateur	Motor programmer	Motor Programmiervorrichtung	Motore programmatore
M Av. R	Motor program. avance rapido	Moteur du progr.avance rapide	Motor program. rapid advance	Motor Programmiervorrich. schneller Vorlauf	Motore programmatore avanzamento rapido
M1	Micro programador marcha	Micro du programm. de marche	Micro programmer on	Motor Programmiervorrich. Betrieb	Micro programma. di funzionamento
M2	Micro programador lavado	Micro du programm. de lavage	Micro programmer wash	Motor Programmiervorrich. Waschen	Micro programmatore di lavaggio
M3	Micro programador aclarado	Micro du programm. de rinçage	Micro programmer on	Motor Programmiervorrich. Spülen	Micro programmatore di risciacquo
M4	Micro programador Termo-stop	Micro du programm. Termo-stop	Micro programmer Termo-stop	Motor Programmiervorrich. Thermo-Stop	Micro programmatore Termo-stop
M5	Micro programador avance	Micro du programm. avance	Micro programmer advance	Motor Programmiervorrich. Vorlauf	Micro programmatore avanzamento
P, P1, P5	Presostato	Pressostat	Pressure switch	Druckwächter	Pressostato
P2, P3, P4	Presostato limitador	Pressostat de sécurité	Hi-limit pressure switch	Begrenzer Druckwächter	Pressostato limitatore
RC	Resistencia calderin	Resistance surchauffeur	Boiler heating element	Heizwiderstand Boiler	Resistenza boiler
RT	Resistencia tanque	Resistance cuve	Tank heater	Heizwiderstand Tank	Resistenza serbatoio
Tt	Termostato tanque	Thermostat de cuve	Tank thermostat	Thermostat Tank	Termostato serbatoio
TC	Termostato calderin	Thermostat surchauffeur	Boiler thermostat	Thermostat kessel	Termostato boiler
TSC	Limitador calderin	Limiteur surchauffeur	Boiler Hi-limit	Begrenzer Boiler	Limitatore boiler
TSTP	Termostato termo-stop	Thermostat Termo-stop	Termo-stop Thermostat	Thermostat Termo-stop	Termostato Termo-stop
V	Electrovalvula llenado y aclarado	Electrovan. remplissage rinçage	Fill and rinse valve	Elektroventil Füllen und Spülen	Elettroval. riempimento e risciacquo
COLOR	COLORES	COULEURS	COLOUR	FARBEN	COLORE
a =	Azul	Bleu	Blue	Blau	Blu
am =	Amarillo	Jaune	Yellow	Gelb	Giallo
am/ve =	Amarillo/verde	Jaune / vert	Yellow / green	Gelb/grün	Giallo/verde
b =	Blanco	Blanc	White	Weiß	Bianco
g =	Gris	Gris	Grey	Grau	Grigio
m =	Marrón	Marron	Brown	Braun	Marrone
n =	Negro	Noir	Black	Schwarz	Nero
na =	Naranja	Orange	Orange	Orange	Arancio
r =	Rojo	Rouge	Red	Rot	Rosso
rs =	Rosa	Rose	Pink	Rosa	Roseo
ve =	Verde	Vert	Green	Grün	Verde
vi =	Violeta	Violet	Purple	Violett	Viola

Z243051000