

<i>Index</i>	<i>Pièce / Part</i>	<i>Désignation</i>	<i>Description</i>
1	59 128	ENSEMBLE CHARNIERE SECURITE BRAS	HINGE ARM ASSEMBLY
2	59 273	ENSEMBLE SECURITE BRAS	LID ARM SAFETY ASSEMBLY
3	501 258S	INTERRUPTEUR SECURITE NORMALEMENT FERME	NORMALLY CLOSED SAFETY SWITCH
4	507 250S	INTERRUPTEUR SECURITE NORMALEMENT OUVERT	NORMALLY OPENED SAFETY SWITCH
5	118 255S	JOINT PLAT DE CHARNIERE	HINGE FLAT SEAL
6	105 912S	CAME INTERRUPTEURS SECURITE	SAFETY SWITCHES CAM
7	118 126S	DOUILLE DE GUIDAGE	BUSHING
8	501 424S	BAGUE ETANCHEITE 20x30x7	SEALING RING 20x30x7
9	119 204S	TUBE DROIT	RIGHT LID TUBE
10	119 205S	TUBE GAUCHE	LEFT LID TUBE
11	59 501	ENSEMBLE ESSUIE COUVERCLE	LID WIPER ASSEMBLY
12	59 395	POIGNEE RACLEUR	BLIXER ARM HANDLE
13	59 502	RACLEURS SOUPLES COUVERCLE (Qté = 2)	LID SOFT WIPER (Qty = 2).
14	59 503	SUPPORT ESSUIE COUVERCLE	LID WIPER SUPPORT
15	59 505	ENSEMBLE SUPPORT COUVERCLE	LID SUPPORT ASSEMBLY
16	59 504	SUPPORT COUVERCLE	LID SUPPORT
17	118 132S	INTERRUPTEUR SECURITE COUVERCLE	LID SAFETY SWITCH
18	59 131	ENSEMBLE PINCES BRAS	ARM CLIPS ASSEMBLY
19	57 069	COUTEAU LISSE	STRAIGHT BLADE ASSEMBLY
20	57 070	COUTEAU CRANTE	COARSE SERRATED BLADE ASSEMBLY
21	57 072	COUTEAU DENTE	FINE SERRATED BLADE ASSEMBLY
22	105 904S	ECROU COUTEAU AVEC BAGUE PLASTIQUE	BLADE LOCKING NUT WITH PLASTIC WASHER
23	105 906S	RONDELLE PLASTIQUE INTEGREE	INTEGRATED PLASTIC WASHER
24	118 201S	BAGUE COUTEAU 10 mm	BLADE SPACER 10 mm
25	118 217S	LAME LISSE	STRAIGHT BLADE
26	118 200S	BAGUE COUTEAU 32 mm	BLADE SPACER 32 mm
27	117 930S	SUPPORT COUTEAU	BLADE SUPPORT
28	118 292S	LAME DENTEE	FINE SERRATED BLADE
29	118 294S	LAME CRANTE	COARSE SERRATED BLADE
30	118 268S	DEMONTE COUTEAU	BLADE DISMANTLING DEVICE
31	119 200S	CLEF DEMONTE COUTEAU	BLADE DISMANTLING WRENCH
32	117 935S	FACE ARRIERE	CASING ACCESS DOOR
33	118 256S	JOINT FACE ARRIERE	CASING ACCESS DOOR SEAL
34	118 127S	FAISCEAU INTERRUPTEUR SECURITE BRAS	LID ARM SAFETY SWITCH HARNESS
35	59 157	ENSEMBLE CLAVIER	CONTROL PANEL ASSEMBLY
36	59 156	ENSEMBLE AXE ARRIERE	BACK TILTING PIVOT ASSEMBLY
37	118 146S	ENTRETOISE AXE ARRIERE	BACK TILTING PIVOT SPACER
38	118 147S	RONDELLE APPUI ARRIERE	BACK THRUST WASHER
39	118 148S	DOUILLE PALIER ARRIERE	BACK BEARING BUSH
40	117 959S	BUTEE BASCULEMENT	TILTING STOP
41	507 250S	INTERRUPTEUR SECURITE BASCULEMENT	TILTING SAFETY SWITCH
42	117 934S	CAISSON	CASING
43	118 186S	PIED ARRIERE	CASING FOOT
44	502 686S	CABLE	POWER CORD
45	515 515S	PASSE FIL	POWER CORD PROTECTOR
46	59 313	CONE DE COUVERCLE	LID FUNNEL
47	59 318	APPUI DE COUVERCLE	LID GUIDE
48	119 259S	BUTEE DE CROCHET	LID LATCH RUBBER STOP
49	119 267S	CROCHET	LID LATCH
50	59 272	ENSEMBLE POIGNEE	HANDLE ASSEMBLY
51	59 517	COUVERCLE	LID
52	119 263S	JOINT DE COUVERCLE	LID SEAL
53	59 155	ENSEMBLE CUVE	BOWL ASSEMBLY
54	118 171S	BOUCHON SECURITE	SAFETY PLUG
55	59 221	ENSEMBLE JOINTS D'ARBRE	SHAFT SEALS ASSEMBLY
56	507 168S	JOINT FACIAL	FACIAL SHAFT SEAL

Index	Pièce / Part	Désignation	Description
57	118 153S	JOINT FOND DE CUVE	BOWL SEAL
58	501 105S	BAGUE A LEVRES 30x40x7	SHAFT SEAL 30x40x7
59	507 050S	JOINT TORIQUE 120x3,5 mm	O-RING 120x3.5 mm
60	59 165	ENSEMBLE APPUIS DE CUVE (Qté = 3)	BOWL SUPPORTS ASSEMBLY (Qty = 3)
61	118 595S	APPUI CUVE PLASTIQUE	PLASTIC BOWL SUPPORT
62	117 922S	DOUILLE PORTE JOINTS	SEALS SOCKET
63	118 151S	JUPE HAUTE	UPPER MOTOR COVER
64	118 155S	DEFLECTEUR MOTEUR	MOTOR DEFLECTOR
65	59 197	ENSEMBLE SUPPORT MOTEUR	MOTOR SUPPORT ASSEMBLY
66	118 157S	ENSEMBLE INTERRUPTEUR SECURITE CUVE	BOWL SAFETY SWITCH ASSEMBLY
67	119 199S	INTERRUPTEUR SECURITE CUVE	BOWL SAFETY SWITCH
68	119 194S	FAISCEAU INTERRUPTEUR SECURITE CUVE	BOWL SAFETY SWITCH HARNESS
69	59 223	ENSEMBLE CAVALIER AXE BASCULEMENT	TILTING PIVOT STAPLE ASSEMBLY
70	118 296S	JUPE BASSE	LOWER MOTOR COVER
71	118 150S	DOUILLE MANCHON	SLEEVE BUSH
72	118 156S	MANCHON 87 mm	SLEEVE 87 mm
73	59 137	ENSEMBLE AXE AVANT	FRONT TILTING PIVOT ASSEMBLY
74	118 189S	PIEtement	STAND
75	117 958S	PIED AVANT	FRONT FOOT
76	59 138	ENSEMBLE LEVIER DE SERRAGE	LOCKING LEVER ASSEMBLY
77	118 142S	POIGNEE DE BASCULEMENT	TILTING HANDLE
78	208 582S	GOUPILLE AXE DE BASCULEMENT	TILTING SHAFT PIN
79	59 439	KIT BAGUE MOTEUR	MOTOR SLEEVE KIT
80	118 143S	RONDELLE D'APPUI AVANT	FRONT THRUST WASHER
81	118 144S	DOUILLE PALIER AVANT	FRONT BEARING BUSH
82	118 166S	ECROU REGLAGE BASCULEMENT	TILTING ADJUSTING NUT
83	117 956S	BOUCHON	COVER
84	59 493	ENSEMBLE COUVERCLE ET JOINT	LID AND GASKET ASSEMBLY
85	59 204	ENSEMBLE ROULETTE AR (NM)	REAR CASTOR ASSEMBLY (NM)
86	59 210	ENSEMBLE ROULETTE AR SEULE (NM)	SLANTED CASTOR ASSEMBLY (NM)
87	59 203	ENSEMBLE ROULETTE AV (NM)	FRONT CASTOR ASSEMBLY (NM)
88	59 209	ENSEMBLE ROULETTE AV SEULE (NM)	STRAIGHT CASTOR ASSEMBLY (NM)

Index	Désignation	Description
A	PLATINE DE PUISSANCE	POWER CONTROL BOARD
M	MOTEUR	MOTOR

Machine	Voltage	A	M
51 331	400/50/3	117 987	303 062S
51 334	380/60/3		
51 337	440/60/3		303 130S

Machine	Voltage	A	M
51 333	220/60/3	117 989	303 125S
51 335	230/50/3		303 109S
51 339	200/50/3 - 200/60/3		303 125S

robotcoupe®

R 23 A

N° de série / Serial number

- 610 - - - - -

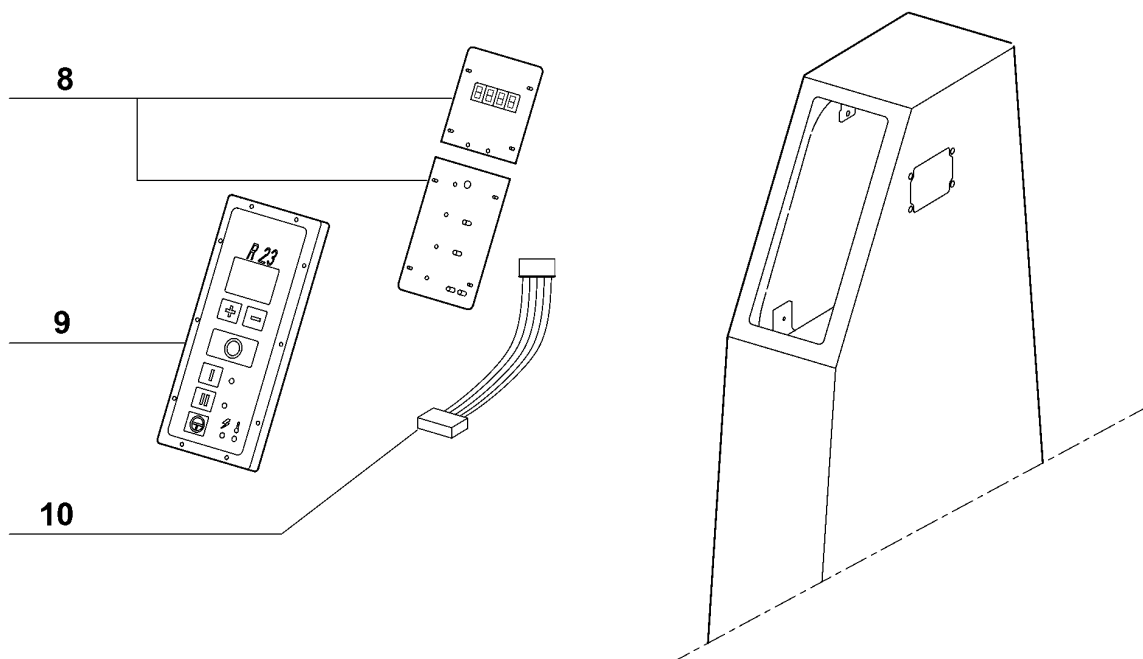
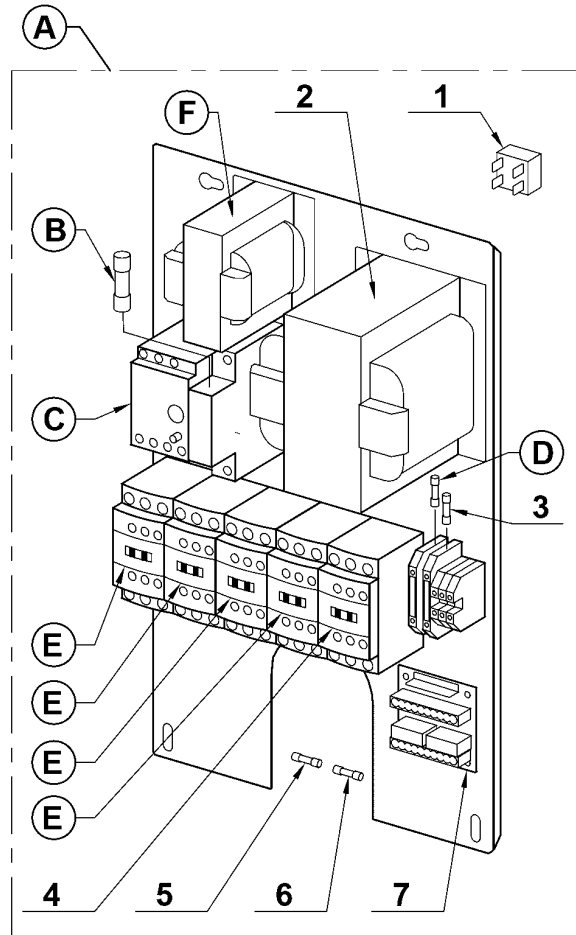

<i>index</i>	<i>Pièce / Part</i>	<i>Désignation</i>	<i>Description</i>
1	511 620S	PONT DE DIODES	RECTIFIER BRIDGE
2	503 353S	TRANSFORMATEUR 48V	TRANSFORMER 48V
3	500 537S	FUSIBLE PRIMAIRE 9/24V	PRIMARY FUSE 9/24V
4	507 174S	CONTACTEUR	CONTACTOR
5	504 253S	FUSIBLE SECONDAIRE 9V	SECONDARY FUSE 9V
6	503 106S	FUSIBLE SECONDAIRE 24V	SECONDARY FUSE 24V
7	117 980S	CARTE DE CONNEXION	CONNECTING BOARD
8	59 482	CARTE DE COMMANDE + TIMER	CONTROL + TIMER BOARD KIT
9	59 157	ENSEMBLE CLAVIER DE COMMANDE	CONTROL PANEL ASSEMBLY
10	117 982S	LIMANDE DE LIAISON	LINK CABLE

<i>Index</i>	<i>Désignation</i>	<i>Description</i>
A	PLATINE DE PUISSANCE	POWER CONTROL BOARD
B	FUSIBLE DE FREINAGE	BRACKING CIRCUIT FUSE
C	RELAIS THERMIQUE	THERMAL OVERLOAD RELAY
D	FUSIBLE PRIMAIRE 48V	PRIMARY FUSE 48V
E	CONTACTEUR	CONTACTOR
F	TRANSFORMATEUR DE COMMANDE	CONTROL TRANSFORMER

Machine	Voltage	A	B	C	D
51 331	400/50/3	117 987	503 355S	503 354S	500 537S
51 334	380/60/3				
51 337	440/60/3				

Machine	Voltage	A	B	C	D
51 333	220/60/3	117 989	503 356S	503 376S	503 108S
51 335	230/50/3				
51 339	220/60/3				

Machine	Voltage	E	F
51 331	400/50/3	503 363S	503 352S
51 334	380/60/3		
51 337	440/60/3		

Machine	Voltage	E	F
51 333	220/60/3	503 364S	507 200S
51 335	230/50/3		
51 339	200/60/3		